

Technical specifications

N° of cylinders	3
Total Capacity (kg)	3500
Motor (HP/KW)	7,5/5,5
Estimated Speed (cm/s)	7/10



MODEL WITH DRIVER ON BOARD

DIMENSIONAL LIMITS

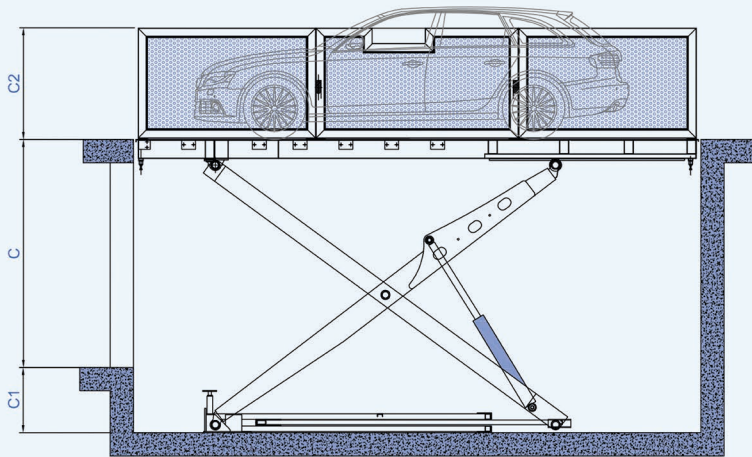

Definition	Ref.	Min (mm)	Max (mm)
Pit lenght	A	5100*	6000*
Platform lenght	A1	5050	5950
Wall distance	A2	25	
Pit width	B	2500*	3000*
Platform width	B1	2400	2900
Clear passage	B2	2300	2800
Wall distance	B3	50	
Stroke (max reach.)	C	3000*	4000*
Extra pit	C1	700*	
Parapets height	C2	1200	1800

* for special requests please contact our technical department

Section View-UP

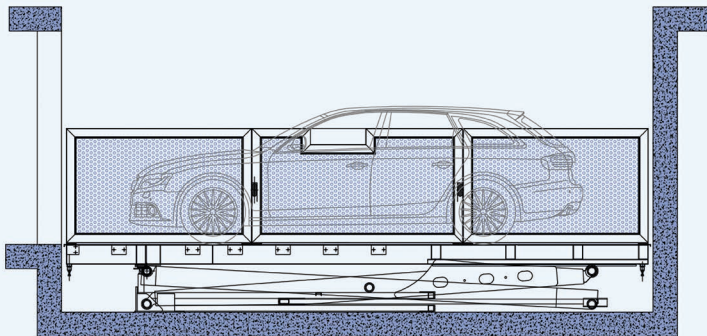

Section View-DOWN

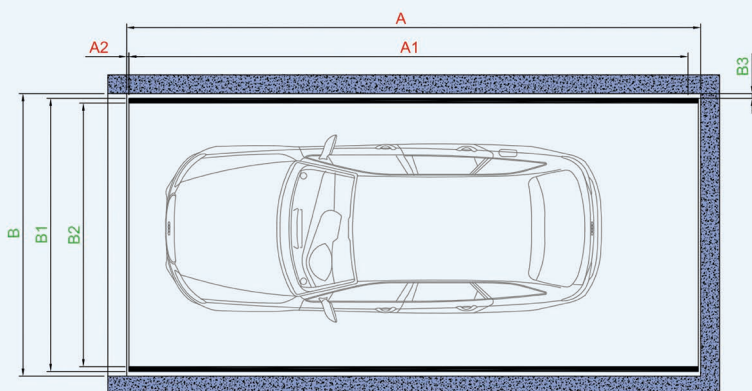

LOADS (KN)

N1	35
N2	3

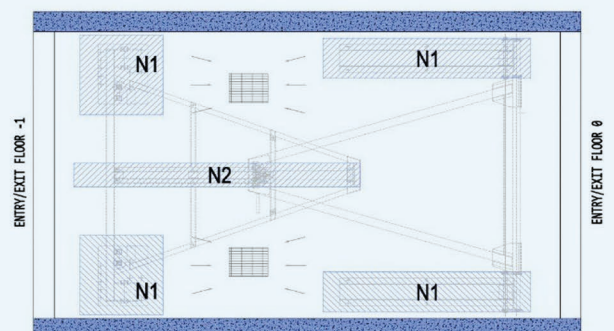

Plan View